

# Rainwater Catchment from a High Tunnel for Irrigation Use

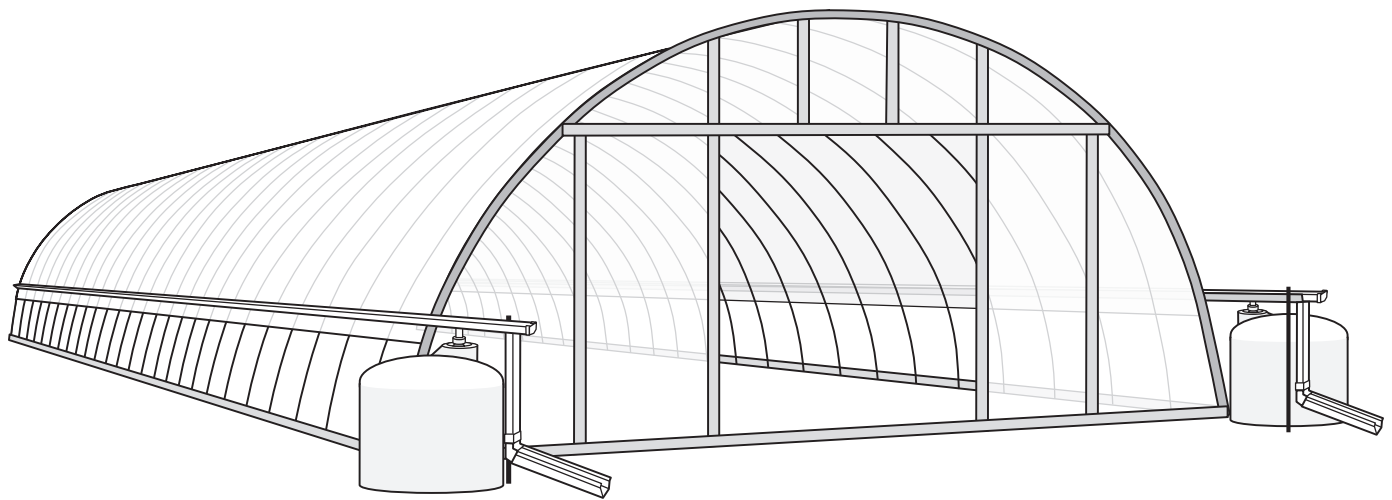

High tunnels, also referred to as “hoop houses,” are simple, plastic-covered, passive solar-heated structures in which crops are grown in the ground. High tunnels resemble greenhouses, but are less expensive to construct and maintain. Fruit and vegetable growers use them to extend the growing season and intensify production in cold climates. The advantages of growing crops in high tunnels rather than in fields are:

- Extended seasons
- Weather protection
- Labor efficiency
- Environmental control
- Reduced incidence of plant diseases
- Improved quality
- Increased revenue per square foot

High tunnel production is considerably different from field production. More detailed attention is required on water and nutrient management, temperature control, crop selection, and continuous production strategies. The covered area in a high tunnel creates a desert-like environment so irrigation is required. Also, since every square foot offers profit potential, high tunnel production requires additional attention to appropriate drainage around the structure. The expanse of a high tunnel yields a large volume of water with every measurable rainfall. Approximately 900 gallons of water

will flow from the roof of a 30' by 96' high tunnel with a half-inch rain event. Unless the high tunnel site is elevated from the surrounding area and/or has drainage tiles installed around the perimeter, water accumulates and creates puddles around the sides of the high tunnel. This can create erosion problems as well as saturated soil on the inside edge of the high tunnel.

Described in this publication is a system to catch, store, and reuse the rainwater for irrigation in the high tunnel. The amount of water collected from periodic rain events often can be enough to irrigate and sustain a high tunnel for a few days to weeks. However, the water supply is not consistent and should not be the only water source for high tunnel crops. The ideal time to install a gutter system is at the time of construction because excess plastic from the cover can be utilized and support boards can be installed efficiently. However, gutters can be retrofitted on existing high tunnels.

The cost of installing rain gutters, rainwater storage tanks, and an electric pump to a high tunnel is estimated at approximately \$1,200 (2011). A solar-powered pumping system will add approximately \$700 to that cost. These estimates do not include

the drip irrigation equipment and lines or the installation labor (approximately 70 hours). Investment in a rainwater catchment system may result in reduced expenses for drainage improvement and site modification and does not require long-term changes in the soil and terrain.

Rainwater catchment and reuse does result in savings on water supply costs. Iowa average monthly rainfall ranges from approximately 2.5 to 5.0 inches per month from April through October. With storage capacity to capture the first half inch of each rainfall event and some losses at the roof edge, an average of 1.5 to 2 inches of rainfall may be captured each month; however, the range may be from less than half an inch to more than 3 inches. Total growing season rainwater capture with storage for the first half inch should be approximately 40-50 percent of the growing season rainfall, or about 10 to 12 inches on the roof area of the high tunnel in Iowa (two 500-gallon tanks collect approximately 20,000 gallons per season from a 30' by 96' high tunnel). Increasing the storage tank size to collect the first inch of rainfall should capture 60 to 70 percent of the growing season rainfall, or about 14 to 17 inches on the roof area of the high tunnel in Iowa (two 1,000-gallon tanks collect approximately 28,000 gallons per season from a 30' by 96' high tunnel).

**NOTE:** Water collected from runoff from the high tunnel should be used only for irrigation through a drip irrigation system. Due to potentially high bacteria levels, it should never be used for consumption or for overhead irrigation of food crops.

The system consists of two components – the catchment and storage and the drip irrigation system.

### Catchment/gutter components for two sides

Item	Quantity
115V industrial diaphragm pump	1
10' long vinyl gutter section	Enough for the length of both sides plus an extra section per side
Vinyl gutter brackets	3 per 10' gutter section
Gutter slip joints	1 per gutter section
Gutter mounting screws	4 per 10' gutter section
Gutter seal lubricant	1 bottle/tube
1.5" pipe straps (conduit clamps) and 1.25" construction screws or bolts and nuts to attach support board to high tunnel frame	1 set per ground post
Vinyl high flow drop outlets	4
Vinyl downspouts 10'	2
Downspout elbow	2
Downspout adapters	2
Vinyl gutter end caps	2
Lumber for gutter support (12' long 2 x 4's)	Enough for the length of one side plus an extra 12 feet
Weatherproof water storage tanks (at least 500 gallon capacity each for 30' by 96' high tunnel)	2
Tank outlet valves	2
Hose adaptors to fit valves	2
Large, inflatable children's vinyl balls (approx. 13" diameter or whatever will fit through the tank top opening)	2
Small machine nuts to thread onto #9 wire (#4-40)	16
Coated #9 wire	25 feet
Garden hoses	2, each long enough to extend from a tank to the pump
<b>Solar-powered pumping system</b>	
12V industrial diaphragm pump	1
12V photovoltaic solar panel with mount	1
12V deep cycle storage battery	1
Solar charge controller	1
Wiring to connect panel, battery, controller	

## Irrigation components

Item	Quantity
200 mesh filter	1
Power switch	1
Pump (see page 5)	1
Power source (electricity or battery)	
8 to 12 PSI pressure regulator	1
Header line ("layflat" hose or ¾" polyethylene tube)	Width of high tunnel
¼" connector tubing	Approximately 2' per drip line
Drip lines	Length varies with number of rows
Drip line emitter valves	2 per line
Adaptors and fittings for: Hose to filter Filter Pump Header line	
Hose clamps	4 to 6
Drip line ends	For each line

Vinyl gutters are recommended because they are assembled with slip joints and clip brackets that allow for easier installation and seasonal removal from the high tunnel. They are also less likely to tear the plastic than metal gutters.

## Water Collection Tanks

Before installing the gutters, select the appropriate-size water tanks for your system. The needed capacity depends on the size of the high tunnel and the amount of water desired to irrigate the crop in the tunnel. Each 1,000 square feet of high tunnel roof will yield approximately 300 gallons of water from a half-inch rain. Gutters and tanks on each side of the tunnel will capture the maximum amount of water possible and water can be drawn alternately for irrigation needs. It is best to have a tank capacity that will nearly empty with each irrigation event. Draining the tanks frequently will prevent excess buildup of algae. Purchase new tanks or used tanks that have held only clean water. Short, wide, plastic tanks with a fairly large opening on the top and a drain near the bottom are ideal. The top of the tank opening should be at least 8 to 12 inches lower than the height of the low end of the gutters. Place the

tanks at the corners of the high tunnel at one end. Level the area for the tank location. Align the tank fill opening so the gutter will drop the water in the center of the opening. In the bottom opening of the tank, install necessary fittings to attach a garden hose and shut-off valve. Water tanks can be lightweight when empty. Secure the tanks to the ground with earth anchors and rope or straps.

## Gutter Installation

The gutter brackets are attached to the high tunnel on a support board that slopes downward to the tank end of the high tunnel. The ribbon board (hip board) on the high tunnel may not be wide enough to accommodate the slope required for the gutters to drain. A 6- to 8-inch drop per 100 linear feet is recommended for the water to flow adequately toward the tank. A dedicated support board, such as a 2 x 4, may need to be installed below the ribbon board. This support board can go near the top of the plastic roll down sides, on the inside of the plastic, or at the top of a drop down ventilation system. Due to the curved sides on a Quonset style high tunnel, split the 2 x 4 diagonally and attach the cut side to the tunnel (See Diagram 1.). This will provide a more vertical surface for attachment of the gutter brackets.

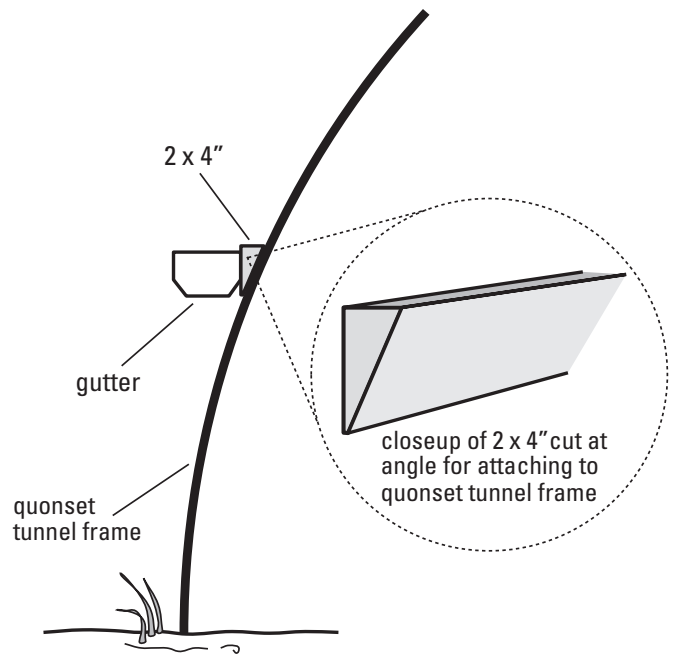

**Diagram 1.** Gutter support board mounted on a Quonset high tunnel.

This diagonal split of the support board is not necessary for gothic style buildings that allow the support boards to be installed just below the ribbon board. If you use full-size (not split) 2 x 4 lumber for a gothic tunnel, the lumber requirements in the table on page 2 will be doubled. Stretch a carpenter's string from one end of the high tunnel as a guide for attaching the support board, allowing for the required drop in elevation. The support board should extend beyond the end of the high tunnel and across the width of the tank. Attach the end of the extended support board to a steel stake or wooden post driven in the ground.

**NOTE:** Before installing the support board, be sure the height on the lowest end of the support board is at least 8 inches higher than the opening on the collection tank. It may be necessary to dig the tank into the ground slightly if it is too tall.

Starting at the high end of the gutter, measure 10-foot intervals along the support board where the center of the slip joints will be installed to splice the 10-foot gutter sections together. Allow for the gutter joint gap specified by the gutter manufacturer. Align the slip joints on a uniform downward slope toward the tank using a string line or sight method to assure uniform slope. Install three gutter brackets, evenly spaced, between the slip joints.

When you reach the tank end of the tunnel, install a drop outlet centered over the tank opening. Install a second drop outlet just beyond the edge of the tank. Install gutter brackets if needed between the drop outlets. Install the gutter sections into the brackets and slip joints using the joint lubricant. Cut sections of gutter to fit the lengths between the last slip joint on the high tunnel and the drop outlet over the tank, and between the two drop outlets. Attach a downspout elbow and downspout to the final drop outlet to direct excess water away from the tank and tunnel (See Diagram 2.).

Because high tunnel buildings typically do not have an overhanging eave or drip edge, provision must be made to get the water off the roof and into the gutter. One simple method is to attach a flap of additional plastic to the tunnel roof, which can hang into the gutter. This flap of plastic may be attached to the roof

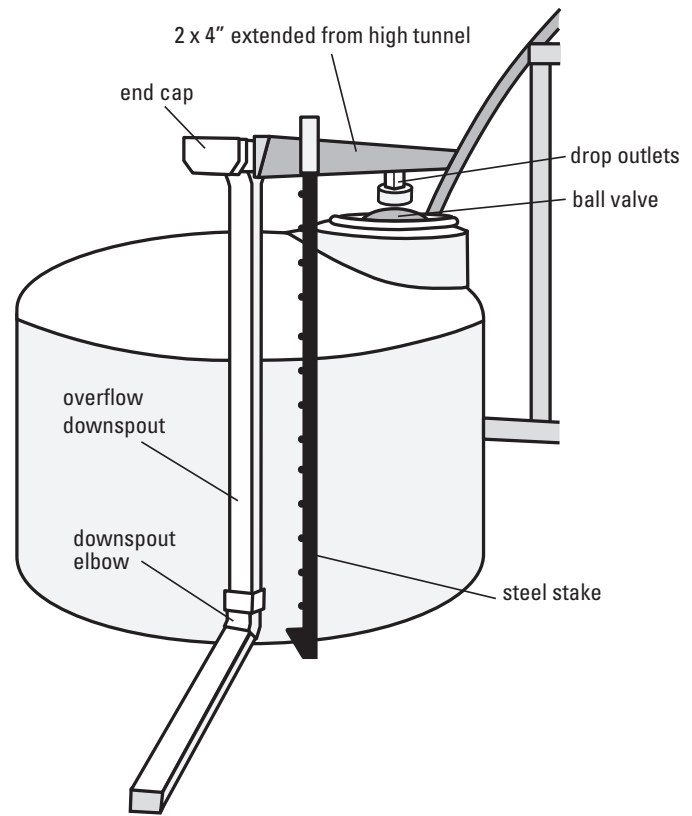

**Diagram 2.** Water Catchment System.

by locking the top edge of the flap under the channel wire on the ribbon board. The flap length will increase as the gutter slopes farther below the channel board. The bottom edge of the flap should nearly touch the inside bottom of the gutter. Another method is to use a uniform width flap that is taped to the tunnel ventilation curtain a few inches above the gutter top edge using tunnel repair tape. Attaching a taped flap around ventilation curtain stay ropes may prove challenging. Taped narrow flaps may resist dislocation by wind better than wider flaps, but taped joints may require more frequent maintenance. Wider flaps attached under channel wires may require less maintenance, but may require weights at the bottom edge or other means of holding the bottom edge inside the gutter during windy conditions. Remember that in freezing climates, winter removal of the gutters may be necessary to prevent ice and snow damage to the gutters and supports.

The plastic film covering on gothic high tunnels end at the ribbon board; the sides are separate pieces of film. After attaching the film covering,

the excess plastic from the roof can be used to direct the water into the gutters. If the plastic has been trimmed close to the channel on existing high tunnels, an additional strip of plastic the length of the tunnel and wide enough to nearly reach the bottom of the inside of the gutter can be attached using channel wire.

### Tank Overflow Valve

An overflow valve diverts excess water away from the tank and into a waterway or other containment or holding apparatus. Simple float valves using large, vinyl, inflatable child's balls are easy to install and effective for this purpose. For each tank, select a large ball that will fit in the opening of the tank. A basket can be made out of #9 wires bent into U shapes. Make the basket deep enough to accommodate the ball and about 4 to 6 inches above the ball for the water to flow from the drop outlet above the tank. Thread the end of the wires so the basket can be attached to the upper lip of the tank with small machine nuts. Attach a downspout adapter to the end of the drop outlet over the tank opening using small screws and seal the joints to prevent water from leaking after the valve closes (See Diagram 3.).

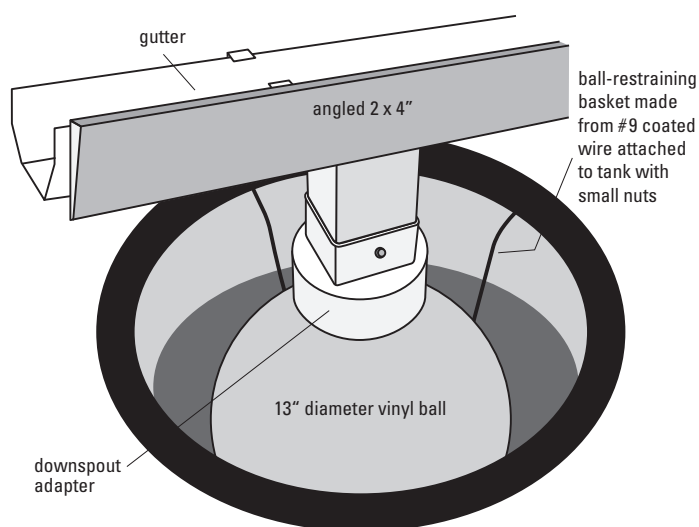

**Diagram 3.** Ball Valve in Tank.

**How it works:** As the water level nears the top of the tank, the floating ball in the basket will rise and eventually seal against the downspout adapter, preventing more water from entering the tank. Any additional

water flows over the blocked drop outlet to the next drop outlet and downspout for transfer to another holding tank or surface drainage away from the high tunnel.

### Pumping System

Recycling collected water through an irrigation system requires a pump to pressurize the water. For drip irrigation systems, small electric diaphragm pumps work well. Size the pump to match the irrigation flow rate (gallons per minute) required for the irrigation system. If the flow rate of the pump is higher than the irrigation system flow capacity, use a self-limiting pressure switch pump to avoid excessive pressure build-up or rapid on-off cycling of the pump. Precede the pump with a 200-mesh filter to remove debris that may accumulate in the storage tanks.

When electric power is not available, a solar-powered 12-volt or 24-volt DC pump may be used. Connect the pump to a deep-cycle battery of the proper voltage. Appropriate battery capacity (amp-hours) can be estimated by multiplying the pump current rating (amps) by the number of pumping hours between battery charging times, with a safety factor built in. For example, if the pump draws 3 amps and you expect to pump 7 hours per day, and you want to be able to pump 2 days without the need to recharge the battery—this would require  $7 \times 3 \times 2 = 42$  amp-hours of battery capacity. Allowing for only 50 percent discharge of the battery, you would look for a battery with at least 84 amp hours of capacity.

Consult with a solar panel provider to select a solar panel appropriate for recharging the battery. Or estimate the needed panel capacity by matching the solar panel (or group of panels) voltage to the battery voltage and dividing the battery capacity (volt-amps) by the number of hours you would like to allow for battery charging. For example, if the battery capacity is 84 amp-hours and you would like to allow two 10-hour days for charging, your solar panel or panel array would need to provide  $84/20 = 4.2$  amps of current for charging. These estimating methods are only rough approximations. Solar panel providers may have more precise estimating methods.

Solar panel charging performance can be enhanced with the addition of a solar charge controller. Charge controllers allow charging to occur in lower sunlight intensities and prevent battery power from bleeding back to the solar panels at night. Refer to recommendations from manufacturers and suppliers to select an appropriate charge controller.

## Maintenance

**Summer care** – Maintain the gutter system by periodically checking for leaks or obstructions. Check the flaps of plastic film that divert the roof water into the gutters to make sure they are intact and properly positioned. Sunlight and warm water temperatures may encourage algae growth in the water storage tanks. Check and flush the filter at the pump each time you irrigate with the collected water. Using the stored water at the first opportunity and shading the top of the storage tanks may help limit algae growth. Check the overflow valve and excess water diversion system weekly to make sure all parts are operating properly. If you use a solar pump and charging system, monitor the charge status of your battery after pumping events and keep your solar panels clean and properly positioned. Monitor the performance of the pump by recording the time required for pumping a known number of gallons from the storage tanks. If the pump performance is lower than expected, check your filters, pressure regulators, and lines to make sure they are clean and free of kinks or obstructions.

**Winterization** – In freezing climates, it may be necessary to remove the gutter system in the winter to prevent damage to the gutters from ice and snow. Snow and ice may slide quickly off the plastic roof, damaging the gutters and mounting brackets. Vinyl gutter sections can be removed from the gutter mounting brackets and slip joint connectors and stored for the winter. Gutter mounting brackets themselves may be left on the high tunnel and are less likely to be damaged by snow and ice. Drain the storage tanks as much as possible prior to freezing temperatures and remove or drain the pump and all plumbing. For solar systems, store the battery in a shop or garage for the winter. Solar panels may be removed and stored for the winter or left in place if the electrical leads are shorted together to prevent the panels from overheating.

## Drip Irrigation System

The covered high tunnel creates a desert-like environment that requires regular irrigation. Drip irrigation is an efficient and accurate way to water crops in a high tunnel. It uses a low flow rate and supplies water only to the root zone of the plants. Drip irrigation is often used with plastic mulch for transplanted crops to conserve moisture and create a more consistent moisture level in the soil.

The drip tape requires a low pressure, 8 to 12 psi, at the main line. The water pressure can be maintained with a low flow pressure regulator after the pump and before the header line. A pressure regulator reduces incoming water pressure to a set pressure usable by a drip system. It is used when the incoming pressure is too high for the emitters or fittings. The flow rate of the regulator should be matched with the system.

The header line, a layflat hose or a ¾-inch polyethylene tube, is connected to the pump with appropriate-sized fittings. The lateral lines or drip lines, such as T-tape®, run the length of the rows (under the plastic mulch) and are typically attached to the header line with ¼-inch tubing and valve fittings (See Diagram 4, page 7).

It is necessary to have a “back up” line from your primary water source for use during dry periods. This line can be attached to the drip system by bypassing the pump.

To learn more about the use of drip irrigation in a high tunnel, refer to the Iowa High Tunnel Fruit and Vegetable Production Manual listed under additional resources.

## Additional Resources

Naeve, Linda, Henry Taber, Eldon Everhart, Donald Lewis, and Ray Hansen. 2010. *Iowa High Tunnel Fruit and Vegetable Production Manual*. Iowa State University. Available to download as a pdf at <https://store.extension.iastate.edu/ProductList.aspx?Keyword=high%20tunnel>

<http://www.hightunnels.org>

<http://www.iowaproduce.org>

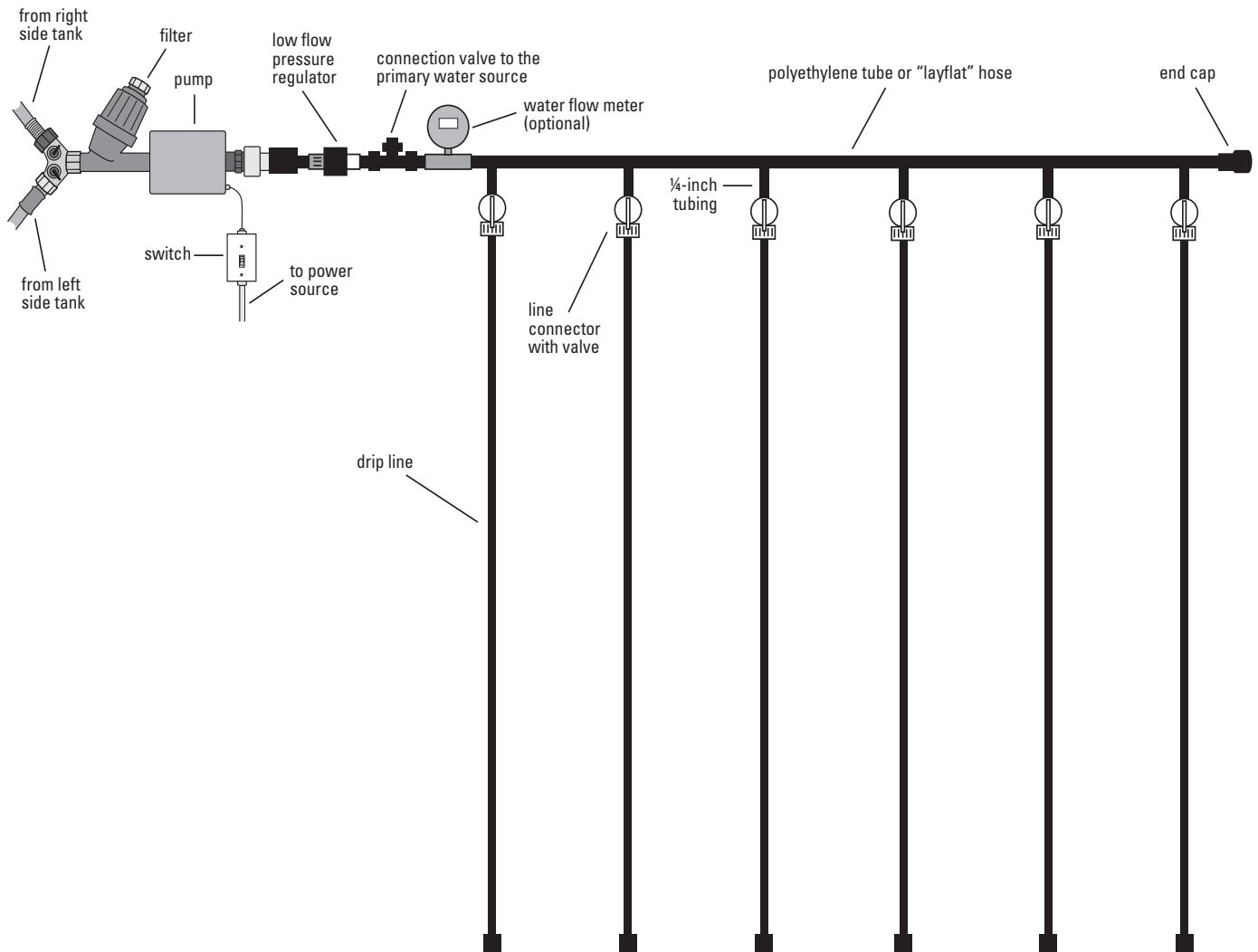

**Diagram 4.** An Example of a High Tunnel Drip Irrigation System using Harvested Rainwater.

This project is supported by a competitive grant from the Ecology Initiative of the Leopold Center for Sustainable Agriculture. For more information, go to [www.leopold.iastate.edu](http://www.leopold.iastate.edu), or call (515) 294-3711.

Written by Shawn Shouse, Extension Agriculture Engineer, and Linda Naeve, Extension Program Specialist.



...and justice for all

The U.S. Department of Agriculture (USDA) prohibits discrimination in all its programs and activities on the basis of race, color, national origin, age, disability, and where applicable, sex, marital status, familial status, parental status, religion, sexual orientation, genetic information, political beliefs, reprisal, or because all or part of an individual's income is derived from any public assistance program. (Not all prohibited bases apply to all programs.) Persons with disabilities who require alternative means for communication of program information (Braille, large print, audiotape, etc.) should contact USDA's TARGET Center at 202-720-2600 (voice and TDD). To file a complaint of discrimination, write to USDA, Director, Office of Civil Rights, 1400 Independence Avenue SW, Washington, DC 20250-9410, or call 800-795-3272 (voice) or 202-720-6382 (TDD). USDA is an equal opportunity provider and employer.

Issued in furtherance of Cooperative Extension work, Acts of May 8 and June 30, 1914, in cooperation with the U.S. Department of Agriculture. Cathann A. Kress, director, Cooperative Extension Service, Iowa State University of Science and Technology, Ames, Iowa.